

VL Series Needle Valve

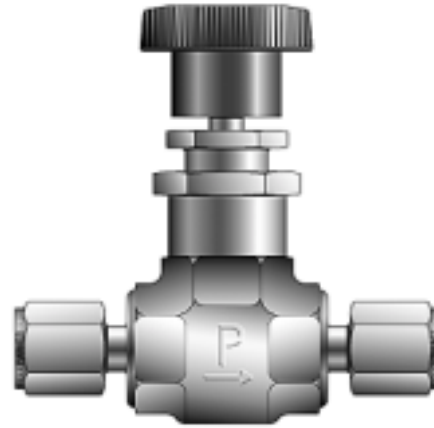

MAXIMUM WORKING PRESSURES AND TEMPERATURE

Maximum Pressure	Maximum Temperature
600 psi at 70 °F 4.1 MPa at 21 °C	600 psi at 300 °F 4.1 MPa at 149 °C

Always consult your authorized Parker representative if questions arise. The arrow on the Valve Body indicates the normal direction of flow.

PACKING ADJUSTMENT

Packing adjustment may be necessary depending on the many varied uses for the Valve. It is recommended an adjustment be made shortly after the initial installation and just prior to flow start-up.

1. Turn the Stem to the full OPEN position, finger-tight.
2. Loosen the Locknut from the Valve Body.
3. Tighten the Bonnet using a 9/16 inch hex wrench to 20 in-lbs.
4. Tighten the Locknut onto the Valve Body approximately 1/8 turn past finger tight.



Figure 1: VL Series Needle Valve Cross Sectional View

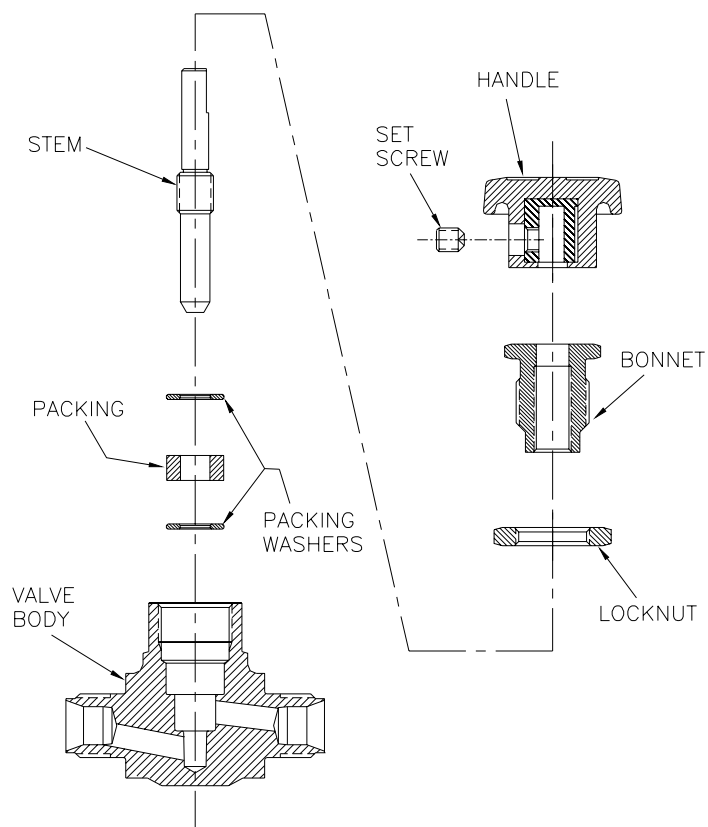

Figure 2: VL Series Needle Valve Exploded View

DISASSEMBLY

WARNING: MAKE CERTAIN THE SYSTEM IN WHICH THE VALVE IS INSTALLED IS DRAINED AND/OR EXHAUSTED OF ALL PRESSURE BEFORE STARTING VALVE REMOVAL OR DISASSEMBLY. FAILURE TO DO SO CAN CAUSE DEATH, PERSONAL INJURY AND PROPERTY DAMAGE.

1. Verify that the Needle Valve Maintenance Kit being used is appropriate for the Valve's size and service requirements. Always contact your authorized Parker representative if any questions arise.
2. Remove the Handle by turning the Set Screw counter-clockwise with a 5/64 inch allen wrench.
3. Loosen the Locknut from the body by turning counter-clockwise with a 11/16 inch hex wrench.
4. Remove the Bonnet from the Body by turning counter-clockwise with a 9/16 inch hex wrench.
5. When the Bonnet is removed, the Locknut, Stem and possibly packing and packing washers will also disengage from the Valve Body.
6. Remove the Packing and Packing Washers from either the Stem or inside the Valve Body.
7. Unthread the Stem from the Bonnet.

REASSEMBLY

1. Make certain all parts are free of dirt or other contamination before starting reassembly of the Valve.
2. Secure the Body in an assembly fixture.
3. Apply a liberal amount of lubricant, as consistent with the Valve's service requirements, to the Stem and Bonnet threads.

Note: Power threads must be covered with lubricant.

4. Thread the Stem into the Bonnet. This is accomplished by inserting the top of the stem into the bottom of the Bonnet.
5. Place the Packing and Packing Washers into the Valve Body as seen in Figure 2.
6. Thread the Locknut onto the Bonnet.
7. Thread the Bonnet into the Valve Body until hand tight. Insure the Stem is in the complete open position to avoid damage to the seat and that the Locknut is threaded completely onto the Bonnet such that it does not prohibit the insertion of the Bonnet.
8. Torque the Bonnet in the Body by turning the Bonnet clockwise with a 9/16 inch torque wrench to 20 in-lbs.
9. Tighten the Locknut to the Valve Body by turning the Locknut clockwise with a 11/16 inch hex wrench until it is snug.
10. Re-install the Handle by threading the Set Screw clockwise into the Handle with a 5/64 inch hex wrench.
11. Turn the Valve Handle through at least one (1) "Open and Close" cycle to verify proper operation of the Stem's threads.
12. Reject and rebuild any Valve exhibiting rough or irregular stem operation. Always contact your authorized Parker representative if questions arise.

VALVE CONNECTOR MAKE-UP INSTRUCTIONS

MALE AND FEMALE PIPE PORTS

Wrench flats are provided on the Valve Body. It is recommended a smooth-jawed wrench or vise be used to grip the Valve Body.

1. On the male threaded part of the connection, apply a high quality pipe joint compound or PTFE tape made for this purpose. When PTFE tape is used, it is recommended two full turns of tape be applied. PTFE tape should not be overhanging or covering the first thread
2. Engage the Valve and the other component part together, until hand-tight.
3. With a proper wrench, holding both the Valve and the component part, continue to tighten to achieve a leak-tight joint.

ULTRASEAL CONNECTIONS

1. Insert the proper O-Ring into the UltraSeal fitting's O-Ring groove. Position the UltraSeal gland sealing face against the O-Ring, and then advance the Nut to a finger-tight position.
2. A positive seal is obtained by advancing the Nut no less than 1/4 turn from the finger-tight position. Proper UltraSeal make-up is achieved when a sharp rise in required application torque occurs, which indicates proper seal face contact and O-Ring seal compression into the UltraSeal groove.

VACUSEAL CONNECTIONS

1. A positive seal is obtained by advancing the Nut 1/8 turn from the finger-tight position.
2. A new gasket should be installed upon each fitting re-make to insure system pressure integrity.

TUBE FITTING CONNECTIONS

1. Insert the tube into the Valve port until the tube bottoms out in the Valve Body. Care should be exercised to insure the tube is properly aligned with the Valve Body and port.
2. Normal make-up for US Customary port sizes 1 thru 3 (1/16 thru 3/16 inch) and SI port sizes 2 thru 4 (2 thru 4 mm) is 3/4 turn from finger tight. Normal make-up for US Customary port sizes 4 thru 16 (1/4 thru 1 inch) and SI port sizes 5 thru 25 (5 thru 25 mm) is 1 1/4 turn from finger tight. For larger port sizes consult Parker Ferrule Presetting Tool Instructions.

PLEASE FOLLOW THE ABOVE DIRECTIONS FOR COUNTING THE NUMBER OF TURNS FOR PROPER FITTING MAKE-UP. DO NOT MAKE-UP TUBE FITTINGS BY TORQUE OR "FEEL". VARIABLES SUCH AS TUBING AND FITTING TOLERANCES, TUBE WALL THICKNESS, AND THE LUBRICITY OF NUT LUBRICANTS CAN RESULT IN AN IMPROPERLY ASSEMBLED TUBE FITTING CONNECTION.

A -Two ferrule A-LOK® compression port



Z -Single ferrule CPI™ compression port



F -ANSI/ASME B1.20.1 Internal pipe threads

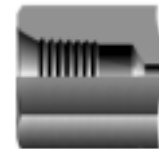

V -VacuSeal face seal port



Q -UltraSeal face seal port



M -ANSI/ASME B1.20.1 External pipe threads



WARNING

FAILURE OR IMPROPER SELECTION OR IMPROPER USE OF THE PRODUCTS AND/OR SYSTEMS DESCRIBED HEREIN OR RELATED ITEMS CAN CAUSE DEATH, PERSONAL INJURY AND PROPERTY DAMAGE.

This document and other information from Parker Hannifin Corporation, its subsidiaries and authorized distributors provide product and/or system options for further investigation by users having technical expertise. It is important that you analyze all aspects of your application and review the information concerning the product or system in the current product catalog. Due to the variety of operating conditions and applications for these products or systems, the user, through its own analysis and testing, is solely responsible for making the final selection of the products and systems and assuring that all performance, safety and warning requirements of the application are met.

The products described herein, including without limitation, product features, specifications, designs, availability and pricing, are subject to change by Parker Hannifin Corporation and its subsidiaries at any time without notice.

ALL PARKER VALVES MUST PASS A RIGID OPERATIONAL AND LEAKAGE TEST BEFORE LEAVING THE FACTORY. IT IS RECOMMENDED AFTER ANY REASSEMBLY, THE VALVE SHOULD BE TESTED BY THE USER FOR OPERATION AND LEAKAGE. IF THESE INSTRUCTIONS ARE NOT FULLY COMPLIED WITH, THE REPAIRED PRODUCT MAY FAIL AND CAUSE DAMAGE TO PROPERTY OR INJURY TO PERSONS. PARKER HANNIFIN CANNOT ASSUME RESPONSIBILITY FOR PERFORMANCE OF A CUSTOMER SERVICED VALVE.

